

MotorGuide®

REPAIR PARTS

Models: **LAZER II**
ELECTRIC STEER

L62ES AG62ES

SPECIFICATIONS:

Year of Intro	1998
Thrust	62LBS
Volts	24VDC
Amp Draw	0 to 33 amps
Mount	20 Bow
Speeds	Variable

QUICK REFERENCE PARTS GUIDE:

MOSFET	JF096-08
Motor Seal Kit	6220
Transmitter	NP169-02

PARTS ORDERING & TECH ASSISTANCE

MotorGuide Consumer Relations
Phone 918-831-6989
Fax 800-982-8093

Returned Goods must be accompanied with a Returned Goods Authorization. Contact MotorGuide Consumer Relations to obtain RGA.

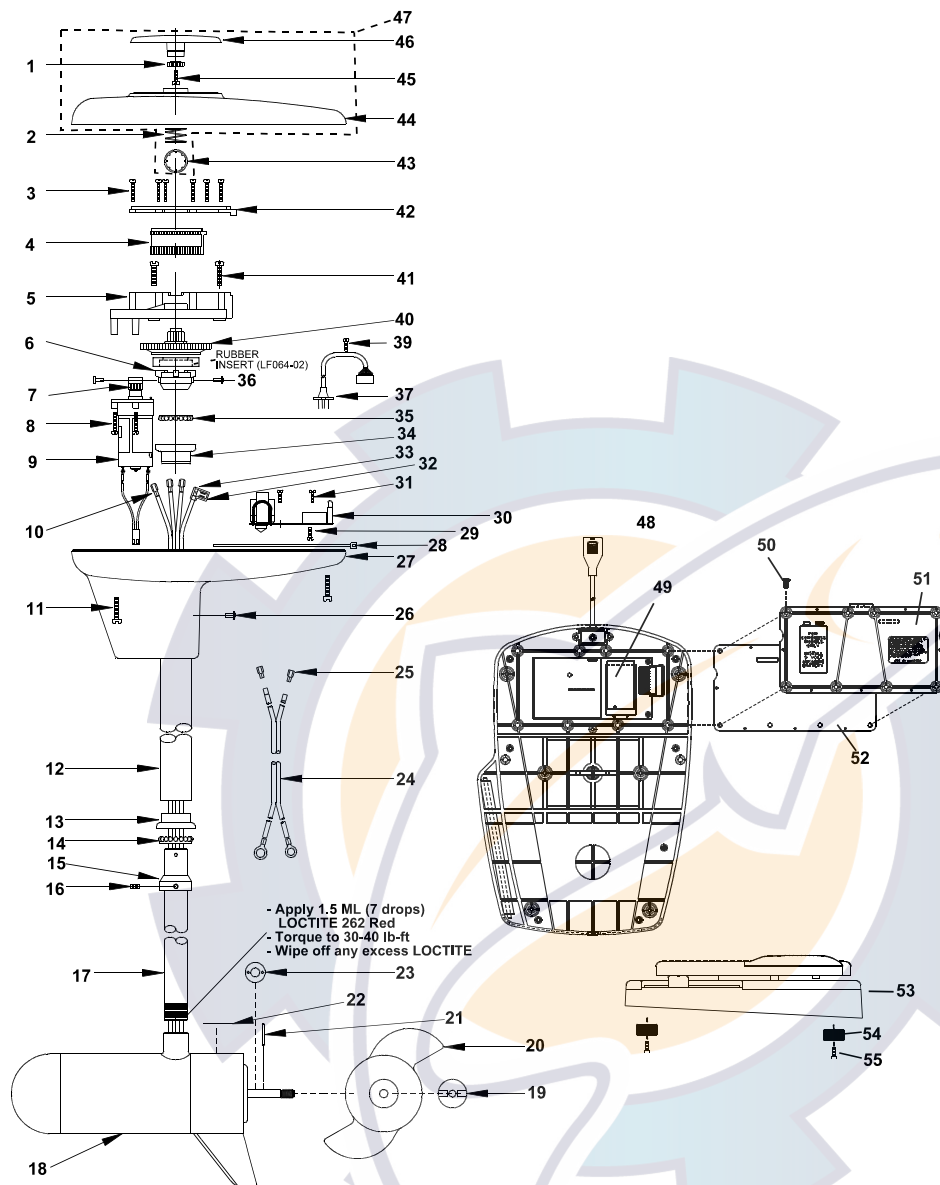

- Apply 1.5 ML (7 drops) LOCTITE 262 Red
- Torque to 30-40 lb-ft
- Wipe off any excess LOCTITE

KEY#	PART#	DESCRIPTION	KEY#	PART#	DESCRIPTION	KEY#	PART#	DESCRIPTION	
1	LF069-04	LAZER GEAR/INDICATOR	22	LF060-04	LOWER UNIT DECAL LAZER	47	LF053-29	LAZER II GENERIC T/H COVER	
2	LF014-01	SPRING/INDICATOR	23	RK171-01	NYLON WASHER .125" THICK	48	LF053-31	AUTOGUIDE GENERIC T/H COVER	
3	LF141-02	SCREW #4 X 7/8	24	LF328-01	BATTERY CABLE ASY	49	NP327-03	CONTROL CABLE	
4	LF125-01	RACK	25	PM160-01	TERMINAL	50	NP157-04	LAZER II INTERFACE BD ES	
5	LF126-01	RACK GUIDE	26	LF111-02	POP RIVET .126-.187 D6	51	NP157-06	AUTOGUIDE INTERFACE BOARD ES	
6	LF064-01	COLUMN COUPLER	27	LF004-02	T/H BASE	52	XF141-06	#6X32X7/16 SCREW	
7	LF068-03	PINION GEAR	28	AF030-01	CABLE TIE	53	NP012-01	LAZER II BATTERY DOOR	
8	LF141-02	SCREW #4 X 7/8	29	AF141-01	SCREW, SELF TAPPING	54	NP079-02	LAZER II DOOR GASKET	
9	LF3126-02	DRIVE MOTOR ASSY 24V	30	LF157-02	LAZER II 24V ES/RF BOARD	55	NP300-10	LAZER II PEDAL ASY	
10	PM160-01	TERMINAL	31	LF157-07	AUTOGUIDE 24V ES/RF BOARD		NP300-15	AUTOGUIDE ES PEDAL ASY	
11	LF141-04	SCREW #8 X 1"	32	AF141-01	SELF TAPPING SCREW		54	XP023-01	FOOT PEDAL PADS
12	AF165-06	(46") OUTER TUBE	33	BR161-03	20-14 FLAG TERMI/STRIP G2		55	XF135-01	SCREW, PAD
13	AF165-07	(30") OUTER TUBE	34	AT080-01	INSULATING SLEEVE				
14	AF165-08	(36") OUTER TUBE	35	FM007-01	BEARING CUP				
15	AF165-01	(13") OUTER TUBE	36	FM005-01	BALL BEARING				
16	FM007-01	RETAINER/ BEARING CUP	37	LF111-01	POP RIVET .376-.500 D6				
17	FM005-01	BEARING	38	LF327-02	HOUSING CABLE				
18	UF397-02	62 # F/O MOTOR	39	IR133-01	SELF TAPPING SCREW				
19	AR099-01	PROP NUT	40	LF069-08	COLUMN GEAR/POWDER MET				
20	AF124-10	3.5 NINJA 3 BLADE PROP	41	LF141-03	SCREW #8X3/4				
21	BR102-01	PROP DRIVE PIN	42	LF127-01	RACK GUIDE COVER				
			43	LF098-01	TINNERMAN CLIP				
			44	LF053-29	LAZER II GENERIC T/H COVER				
			45	LF053-31	AUTOGUIDE GENERIC T/H COVER				
			46	LF141-06	SCREW #6X1/2 PLASTIC				
				LF078-09	LAZER INDICATOR				

PARTS NOT ILLUSTRATED

LF078-02	RAISED SECONDARY INDICATOR
LF141-01	SCREW, SECONDARY INDICATOR
LF057-01	INDICATOR DECAL
LF056-26	L62ES TOP HOUSING DECAL
LF056-34	AG62ES TOP HOUSING DECAL

Models:
L62ES
AG62ES

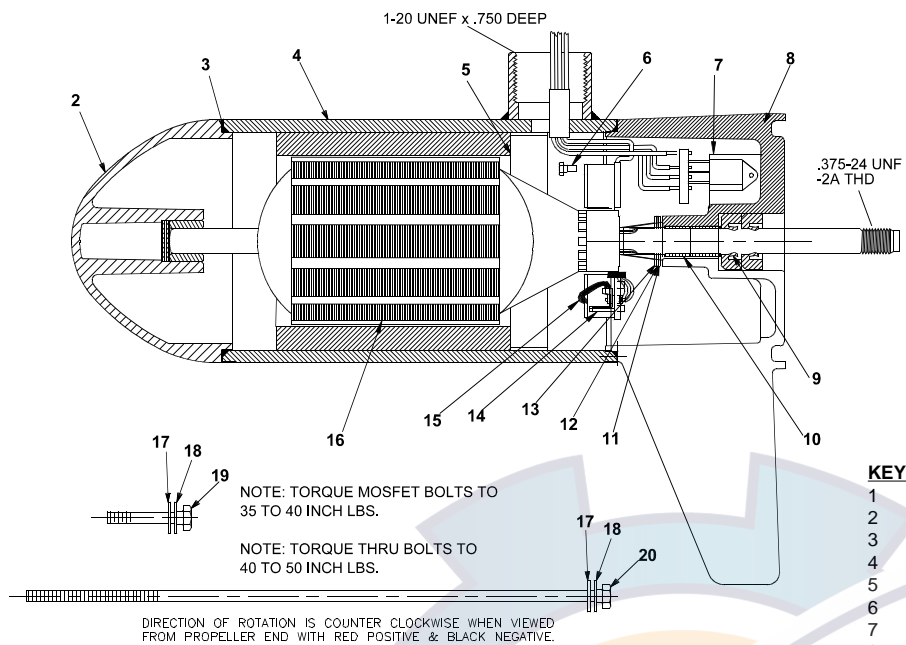

NOTE: TORQUE MOSFET BOLTS TO 35 TO 40 INCH LBS.
NOTE: TORQUE THRU BOLTS TO 40 TO 50 INCH LBS.

DIRECTION OF ROTATION IS COUNTER CLOCKWISE WHEN VIEWED FROM PROPELLER END WITH RED POSITIVE & BLACK NEGATIVE.

KEY	QTY	DESCRIPTION	PART NO.
1	X	MOTOR	UF397-02
2	1	NOSE CAP	JF3212-01
3	2	O RING SEAL	MR217-01
4	1	HOUSING ASY	UF3210-01
5	1	RETAINER	JF233-01
6	2	BRUSH CARD SCREW	MR228-01
7	1	DURA AMP MODULE	JF096-08
8	1	COMM CAP	UF3205-01
9	2	SHAFT SEAL	MR223-01
10	1	BEARING	MR206-01
11	1	NYLATRON WASHER	MR226-01
12	1	WASHER	MR227-01
13	1	E RING	MR219-01
14	2	BRUSH SPRINGS	MR214-02
15	1	BRUSH ASY LESS SPRING	UF3201-02
16	1	ARMATURE	UF3207-01
17	4	STATIC SEAL	MR222-01
18	4	THRU BOLT WASHER	MR216-01
19	2	DURA AMP SCREW	MR229-04
20	2	THRU BOLT	MR218-02

WIRING

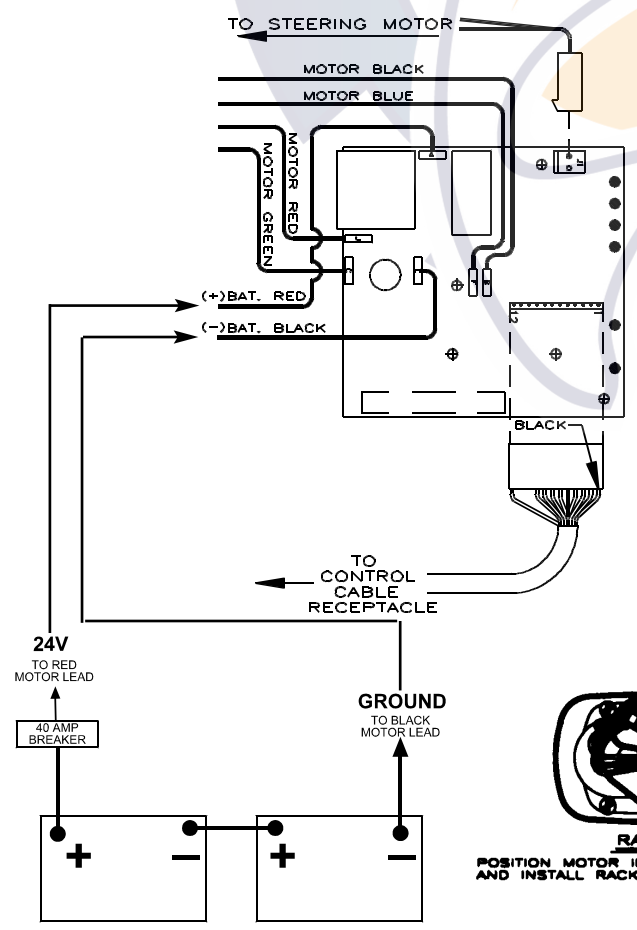

SUBJECT TO DAMAGE BY STATIC ELECTRICITY ASSEMBLE AT STATIC FREE WORK STATION.

Lubricate wire exiting pinion with non washout grease and bend wires flat to clear indicator gear teeth.

Battery cable leads to be bent at 90 degrees. Leads must be at or below top of Control electronics board.

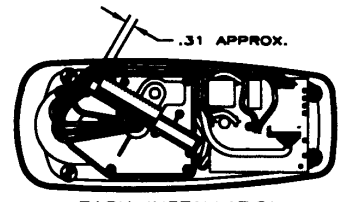

RACK INSTALLATION
POSITION MOTOR IN LINE WITH TOP HOUSING (SEE BELOW) AND INSTALL RACK APPROX. 5/16 FROM END OF TRAVEL

